



PreView[®] Plus Monitor

PVP710

Setup Guide



www.precos.com

TRADEMARKS

The names of actual companies and products mentioned herein may be the trademarks of their respective owners. Any rights not expressly granted herein are reserved.

Contents

Product Description	1
Safeguard Instructions	1
Function.....	3
On Screen Symbols:.....	4
Settings:.....	5
Basic Installation with the PVP710:.....	9
Configuring the PVP710:	9
Understanding Sensor IDs:.....	12
Detections & Triggers*:	12
Setting up Camera Views & Volume:	13
Locking Out the Monitor (Set the Home Screen):	14
Standby Feature:.....	15
Alarm Acknowledge (ACK) Feature:	15
Specifications.....	18
Troubleshooting:	19
Additional Options.....	20
Warranty Information.....	21

Product Description

The PRECO Electronics® PVP710 is an integrated monitor/communication device that operates in conjunction with PRECO Electronics® PreView® radar sensors and PRECO Electronics® ClearPath cameras. When properly configured, the monitor will switch to show the camera view that is associated with the highest priority object detection and will provide visual as well as audio cues to alert the operator to the presence of an object.

Safeguard Instructions

Please read the following cautions carefully before using this product. Following these rules prevent users from damages related to the misuse of the product.

Caution:

- Electrical shock or damage to the product may occur if machine power is not turned off during installation.
- Do not install the monitor closer than 6" (15cm) to a heat emitting source.
- Do not clean exterior with solvents as they may damage the product and could potentially cause a fire.
- Do not mount the unit where it would be subjected to extreme vibration or shock.
- Do not place near a magnet as it may cause undesirable performance.
- Do not disassemble unit as it will void the warranty.

Features

- Water resistant (IP67), Aluminum housing
- 4 Camera input (NTSC/PAL compatibility)
- Multiple display modes (single, 2, 3, 4 split)
- Automatic dimmer sensor
- 7 inch WVGA (800x480) Wide LCD Panel
- Automatic trigger for displays (4)

Contents

Before using this product, please check the contents. If there are missing parts, please contact PRECO Electronics®.

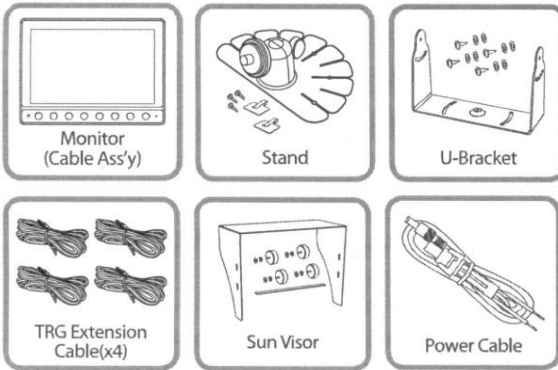

Design and Specifications are subject to change without notice.

Function

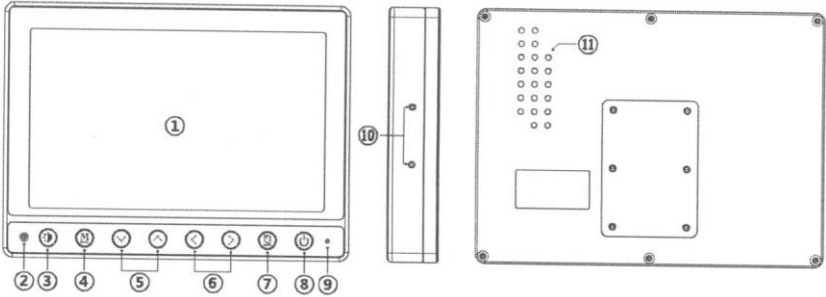

1. LCD Screen – WVGA (800x480)
2. Dimmer Sensor – Automatic brightness control sensor
3. Dimming Button – Select the screen brightness
4. Mode Button – Cycle through camera modes – single, double, triple, quad.
5. Up/Down Buttons – Used to select the different menu functions and cycle through the different camera views
6. Left/Right Buttons – Used to change values for the different menu functions
7. Menu Button – The menu button activates the on screen display (OSD) menus for monitor adjustments. Press button multiple times to cycles through different functions.
8. Standby Button – Enters and wakes the monitor from Standby mode
9. Standby LED – Illuminates to indicate the unit is powered and in standby mode
10. Sun Visor Hole – Sun visor & U bracket installation hole
11. Speaker hole – Speaker hole (Waterproof)

On Screen Symbols:



This symbol indicates that the sensor associated with that camera is powered and communicating with the monitor properly.



This symbol indicates object detection. This symbol will flash and vary in count, size, and color depending on the proximity to the object. Five of these symbols represent immediate proximity to an object.



An arrow will appear in place of the  symbol when an object is detected to inform the operator which sensor is detecting by pointing in the direction of the detecting sensor. The arrow will vary in color relating to the proximity of the object being detected with red representing closest proximity.



This icon will appear in the event of a PreView® radar sensor reporting a BIST (Built In Self Test) error. If this icon appears, the system is in need of repair.



This icon will appear in the event the monitor receives no communication from any sensor. If this icon appears, the system is in need of repair.



This icon will appear in the event of a communication error with a single sensor in a multiple sensor application. If this icon appears, the system is in need of repair.







This icon will appear in the event of a PreView® radar sensor reporting a blockage error. If this icon appears, the sensor needs to be cleaned off.

If any of the above error icons are present PRECO Electronics® recommends ceasing operation of the vehicle until the object detection system is repaired.

Settings:

Video standard system, / PAL conversion





1. Press the  button (2 - 3 times) until the OSD menu [PICTURE SETUP] appears.
2. Press the  or  button to select the value to change and change the value by pressing the  or  button.

NTSC or PAL video can be selected.

PICTURE SETUP

DIMMER	NIGHT
CONTRAST	50
BRIGHTNESS	50
COLOR	50
TINT	50
LANGUAGE	ENGLISH
VIDEO SYSTEM	NTSC
RESET	

Dimmer sensor setting

1. Press the  or  button to select the value to change and change the value, DAY (brighter) / NIGHT (darker) / AUTO (sensor) by pressing the  or  button.



PICTURE SETUP

DIMMER	NIGHT
CONTRAST	50
BRIGHTNESS	50
COLOR	50
TINT	50
LANGUAGE	ENGLISH
VIDEO SYSTEM	NTSC
RESET	

Alternately, pressing the  button to switch between DAY → NIGHT → AUTO → DAY.

* Dimmer is set to AUTO from the factory.

Picture Setup

1. Press the  or  button to select the value to change from CONTRAST to TINT and change the value by pressing the



 or  button.

PICTURE SETUP

DIMMER	NIGHT
CONTRAST	50
BRIGHTNESS	50
COLOR	50
TINT	50
LANGUAGE	ENGLISH
VIDEO SYSTEM	NTSC
RESET	

*Each value is set at 50 from the factory.

Language display selection

1. Press the  or  button to select the value to change and change the value by pressing the

 or  button.

PICTURE SETUP

DIMMER	NIGHT
CONTRAST	50
BRIGHTNESS	50
COLOR	50
TINT	50
LANGUAGE	ENGLISH
VIDEO SYSTEM	NTSC
RESET	

*Language selection: English – French – German – Italian - Spanish

Reset

1. Press the  or  button to move to RESET and then press

 button.

PICTURE SETUP

DIMMER	NIGHT
CONTRAST	50
BRIGHTNESS	50
COLOR	50
TINT	50
LANGUAGE	ENGLISH
VIDEO SYSTEM	NTSC
RESET	

*This will reset the settings to the factory defaults.

Operational Example:

A system has two cameras and two sensors with a single monitor. One camera and sensor are on the vehicle right side and the other camera and sensor are mounted on the vehicle rear. The right side sensor is wired for constant power and the rear sensor power is wired to the reverse lights. The monitor is set up to have a split screen showing both camera views. Please note the top image shows the green "V" logo informing the operator that the sensor associated with that camera is powered and not detecting an object. Also notice that the bottom screen has no symbol indicating that the sensor is not powered:



If the sensor on the right detects an object the monitor will switch to show the right side camera full screen and give detection information.

When the vehicle is put in reverse the monitor will switch to a full screen showing only the rear camera view. At this time the sensor will be powered up by the reverse lights and will give detection information. **Object detection information is only available when the sensors are powered.** See image on next page:



This full screen view will be in effect until vehicle is removed from reverse. At this point, the monitor will return to the home screen (see the **Locking Out** section for more details) showing the rear and right side views in split screen format.

PVP710 Setup - Configuring monitor to communicate with a sensor:

Out of the box, the monitor is only set up to communicate with one PreView® sensor. These instructions will guide you through the process of further configuring the PVP710 for this purpose and also explain how to set up multiple cameras and sensor systems.

Why does the monitor need to be configured?

The PVP710 is designed to communicate with PreView® radar sensors and display detection data on the monitor. When powered, PreView® radar sensors continuously send out data indicating the presence or absence of an object. The monitor and sensor(s) need to be physically connected together as well as the PVP710 monitor configured to accept the radar sensor(s) data.

Basic Installation with the PVP710:

Before we get into how to configure the monitor let's take a look at a basic single sensor and camera installation. The drawing below will detail all of the necessary wiring connections to make this setup work (sensor power connections not included). The rear sensor and camera must always be connected and configured to Camera 1 and the Camera 1 trigger must always be connected to Reverse +V if being used in a reversing application.

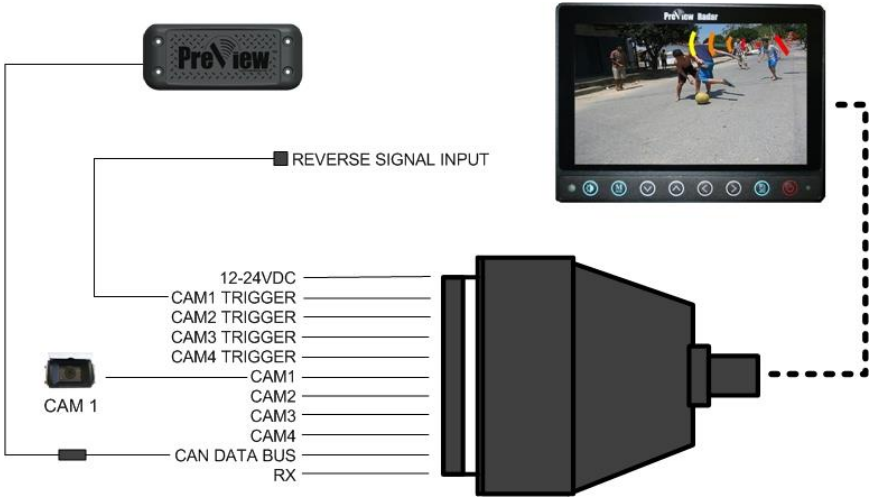

Configuring the PVP710:



The monitor is configured from the factory to communicate with a single rear sensor with an ID of 1, linked to Camera 1. Follow the next few steps to configure the monitor to communicate with multiple sensors and cameras if necessary for your application. **Camera 1 must always be dedicated to the reverse sensor and camera if applicable.**

The first step in allowing the PVP710 to communicate with multiple PreView® sensors is to ensure the monitor is enabled for sensor communication through the [Sensor Enable Menu](#).

Press and hold the  and  buttons simultaneously for 10 seconds until the [Sensor Enable Menu](#) appears: (see image on next page)

SENSOR ENABLE MENU



Press the  or  button to toggle the Sensor Enable ON:

SENSOR ENABLE MENU







The next step is to tell the monitor how to communicate with the sensor(s).

Press the  button to select the **Sensor Setup Menu** and then the  button to enter the submenu.

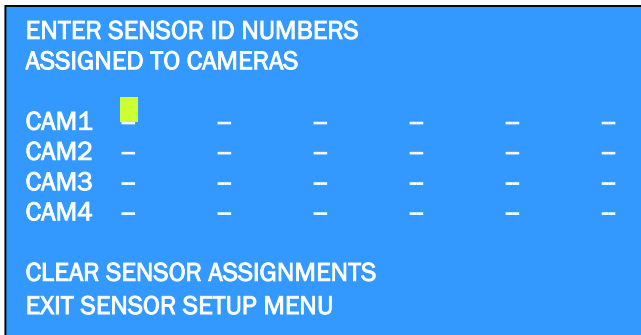
Moving about the **Sensor Setup Menu**:



SENSOR ENABLE MENU

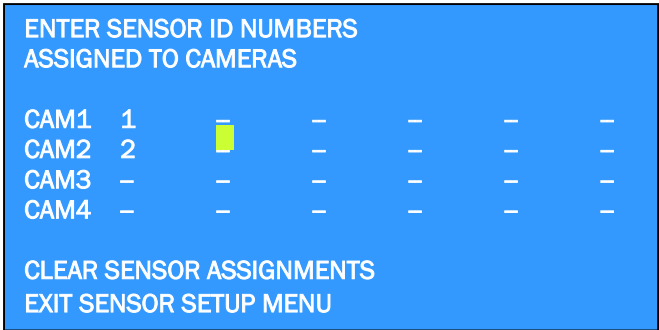

-  and  buttons move the highlighted cursor left or right to select the cell to change
-  and  buttons increment or decrement the sensor identification number (see **Understanding Sensor IDs** on the next page for more information)
- Up to six different sensor IDs can be assigned to a single camera

Using the same example as before we have a two sensor and two camera system. One camera and sensor is on the rear of the vehicle while the other is on the right side. The sensor IDs are not important as long as they are unique (see **Understanding Sensor IDs**). For ease of illustration the sensors IDs will be set to 1 & 2 for the monitor. Please note that a PVST-4000 Service Tool must be used to configure the sensor(s) to these IDs as well (see sensor and PVST-4000 Service Tool user manuals for more information). The **Sensor Setup Menu** should look like this once the IDs are entered:



To exit, press the  button until the **Exit Sensor Setup Menu** is highlighted and then press the  button. Or alternately, the  button can be pressed to exit this menu.

Sensor Diagnostics Menu:

After assigning the proper sensor IDs, the **Sensor Diagnostics Menu** should be checked to verify that the sensor(s) and monitor are communicating properly. **The sensor must be powered in order to communicate with the**

monitor. This menu is accessed by pressing the  button three times (four times if on a split screen view):

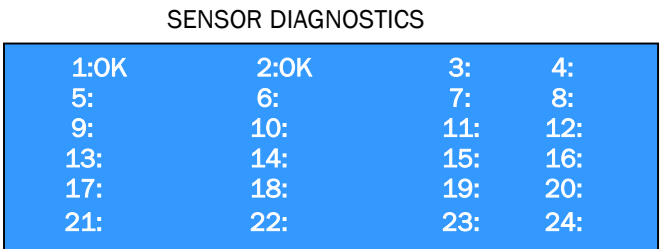

The purpose of this menu is to display the status of all sensors in the system, sorted by sensor ID. One of the following status symbols will be shown next to the sensor ID(s) that is configured:

- “OK” – sensor is functional and communicating properly
- “XX” – sensor is not communicating properly
- “Er” – sensor is communicating properly but is not functional
- “Z1”, “Z2”, “Z3”, “Z4”, “Z5” – sensor is reporting a detection in the corresponding detection zone (Zone 1 is the closest detection zone)

Understanding Sensor IDs:

Sensor IDs are a unique addressing number assigned to each sensor in a system. These unique addressing numbers are needed to allow all of the sensors to communicate through a single communication cable and provide for easier expansion of the system. Please make sure to use the PVST-4000 Service Tool to assign the appropriate IDs to the sensor(s) in addition to setting the IDs in the monitor. There are a couple rules that apply to assigning sensor IDs:

- Every sensor ID must be unique therefore cannot be repeated
- Sensor IDs are limited to numbers between 1 and 24
- The same sensor ID cannot be assigned to multiple cameras

Detections & Triggers*:

Detections and triggers are two different types of events that can cause the monitor to switch to a full screen view of a particular camera. A detection occurs when a properly configured PreView® sensor detects an object and a trigger occurs when one of the four camera trigger wires transition from ground potential to positive voltage potential. Something important to note is that triggers have priority over detections.

Example: Let's use the two camera / two sensor system mentioned earlier in this manual. The sensor on the right side of the truck detects an object and the monitor immediately switches from a split screen view to full screen, showing the detection on the right side. The operator then places the truck into reverse and the monitor immediately switches to show the rear camera and sensor information, regardless of the detection on the right side of the truck.

Trigger & detection priority go in order from smallest camera number to largest camera number, starting from 1 (highest priority) to 4 (least priority). When installing a multiple camera and sensor setup, the same priority logic should be followed. For example, on a truck with two cameras and two





sensors the sensor and camera with the highest priority should be installed as camera 1. **Always connect the camera triggering off of reverse to the camera 1 input.**

Setting up Camera Views & Volume:

Setting up the desired camera view and volume is critical because once the setup is performed the monitor should be locked out. Locking out the monitor prevents the operator from changing any of the settings therefore limiting the effectiveness of this safety/object detection system.

Mirror Set Menu:

Many camera installations will need the image mirrored in order to make the image easily understandable. In order to do this, simply access the **Mirror**



Set Menu by pressing the  button once (twice if currently in a split screen view). In this menu press the  or  button to highlight the camera you wish to change and press the  or  button to toggle between mirrored and normal. You will see these changes take place real time in the background.

Camera Views*:

There are multitudes of camera views available ranging from a single full screen view to several split screen views showing up to 4 cameras at the same time. One of these views needs to be chosen to be set as the home screen. The home screen is the default view for the monitor when the sensor(s) is not detecting an object. To choose which view to have as the home screen, all of the menus must be cleared off the screen. The next step in choosing what view is appropriate is deciding how many cameras you would like to show at one time. The quantity of cameras to show can be

chosen by pressing the  button. Each press of this button will increase the viewed cameras until the max is reached of four. At this point another press of this button will return the monitor to a single camera full screen view.





Once the desired amount of cameras is displayed, they can then be

arranged in several different ways. Press the  or  button to cycle through the different available display arrangements. **Camera views cannot be changed if a trigger is active.**

Split Screen Setup Menu*:

This menu provides the ability to customize which camera to display in a particular quadrant on a split screen setup. To enter this menu, press the

 button once. Use the  or  buttons to navigate to the quadrant

that is desired and press the  to select that quadrant. Now simply use the  or  button to select the camera that is desired to be shown in that quadrant and press the  button to confirm.

*** Applies to multiple camera systems only.**



Setting the Volume:

The next step in setting up the system is to choose what volume the monitor needs to be set at. The volume should be set to where the detection information can be heard above all other in cab buzzers and noises. To

adjust the volume press the  or  button. A popular choice is to set the volume at 75 or higher.

Locking Out the Monitor (Set the Home Screen):



As mentioned earlier it is highly suggested to lock out the monitor to ensure the continued full effectiveness of this safety/object detection system. The

monitor is easily locked out by holding the  and  buttons for five seconds. The LED on the right side of the buttons will illuminate for one second to confirm lock out mode. **Whatever camera view is being displayed when the monitor enters lock out mode will be set as the home screen.** The home screen is important because it dictates what screen the monitor will default to when a sensor is not detecting an object.

When in lock out mode the volume control and ability to switch between split screen views will be disabled. Some menus can still be accessed but there are no settings that can be changed that will hamper the effectiveness of the system. The only views that can be accessed besides the home screen are single camera full screen views. These views can be cycled through by



pressing any of the arrow buttons. Pressing the  button will return the view to the home screen. There is a ten second timeout on any view selected after which the monitor will return to the home screen.

The lock out mode is designed to be permanent and will not be reset with loss of power. The only way to exit lock out mode is to follow the same



procedure as entering the mode, holding the  and  buttons for five seconds. The LED on the right side of the buttons will flash several times to confirm that lock out mode has been exited.

Standby Feature:

This monitor has a standby feature that allows the monitor display to be off until an object is detected or until the vehicle is placed into reverse.

Pressing the  once will put the monitor into this mode. If any sensor other than the rear detects an object the monitor will automatically exit standby and switch to the camera associated with the detecting sensor. Additionally, any time the vehicle is placed into reverse the camera will exit standby mode to show the rear camera. After either of these conditions clear the monitor will automatically go back into standby mode. Standby mode can also be exited at any time by pressing the  button again.

Alarm Acknowledge (ACK) Feature:

The ACK feature allows the operator to acknowledge an alarm when a sensor detects an object. This is particularly useful when a constant sensor detection may occur with the vehicle stopped. When the monitor announces the presence of an object by switching to show the associated camera full screen* and sounding an alarm, the operator has the ability to silence the alarm by pressing any buttons except . Pressing the  button after acknowledging the alarm will return the monitor to the home screen, except when in reverse*.

*** Applies to multiple camera systems only**

Bracket Installation

Installation (U-Bracket)

1. Be sure to place the monitor away from heat sources. Install the monitor stand with the enclosed screws and double sided tape as shown in the picture.
2. Fix the monitor to the monitor stand firmly.

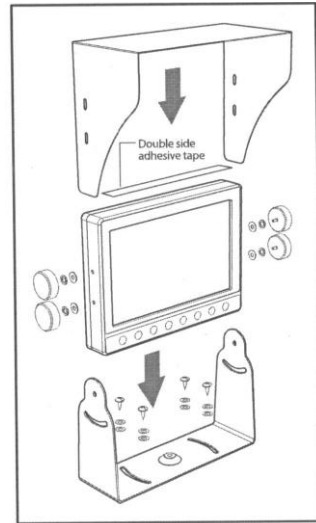

Sun Visor should be installed with 4 screws.

Standard Installation

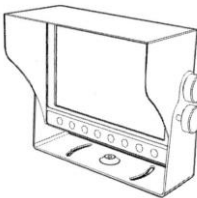

Ceiling Installation

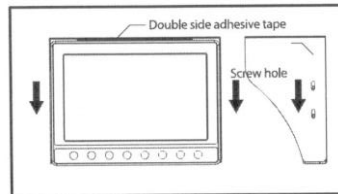
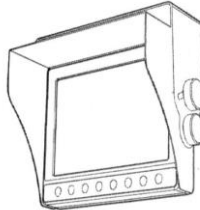

Installation (stand)

1. Be sure to place the monitor away from heat sources. Install the monitor stand with the enclosed screws and double sided adhesive tape as shown in the picture.
2. Fix the monitor to the monitor stand firmly.

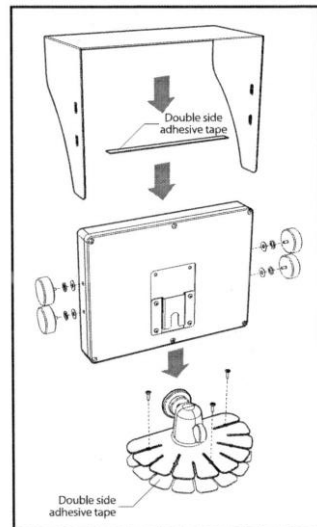
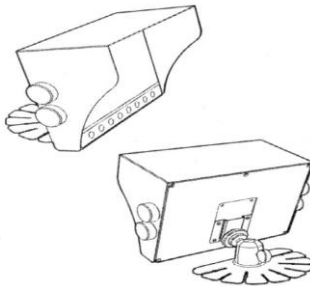

Connection

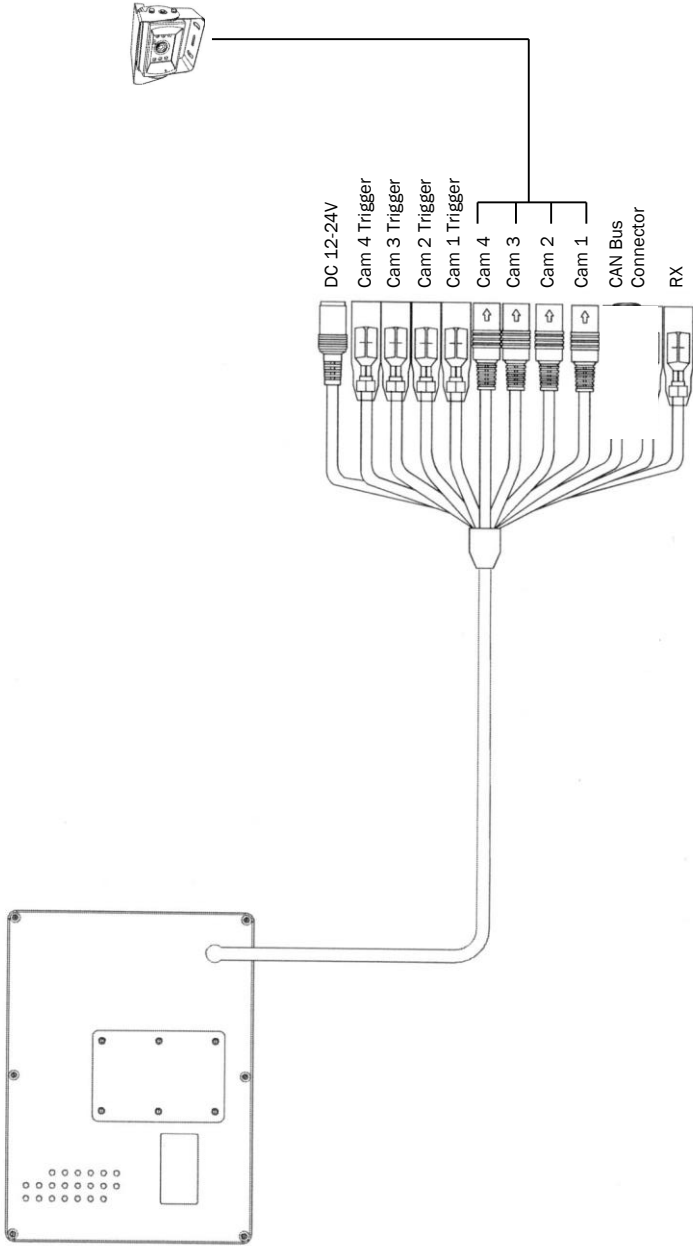

Specifications

LCD Panel	Screen Size	7 inch
	Resolution	WVGA (800x480)
	Brightness	450cd/m ²
	Contrast ratio	400:1
	View Angle (L/R/U/D)	70° / 70° / 45° / 55°
Power Supply	Voltage	DC 12V~24V
	Current	550mA (DC12V, monitor set only)
Input System		NTSC / PAL
Frequency	NTSC	H: 15.734 kHz / V: 59.94 Hz
	PAL	H: 15.625 kHz / V: 50 Hz
Input Signal	Video Signal	Composite Video (CVBS)
	Audio Signal	Mono
Speaker		0.5Watt max.
Language display selection		English, French, German, Italian, Spanish
User Controls (8 button)		Dimmer, Mode, Down, Up, Left, Right, Menu, Power
Operating temperature		-10°C ~ 50°C
Storage temperature		-20°C ~ 70°C
Dimension		180(W) x 133 (H) x 27 (D) mm
Weight		780g (monitor only)

Troubleshooting:

For questions, call +1.844.787.2327 toll free in the USA. Call +1.208.323.1000 or send a fax request to +1.208.323.1034 for outside the USA, or submit an online request at www.precو.com/contact-us/

A safety specialist will respond within 24 hours.

Additional Options:

PreView® Safety Alert System – The PreView® Radar Sensor detects an object in the blind spot. Once the object is detected, PreView® triggers the back-up alarm to either increase the sound of the alarm OR change the beep rate to alert pedestrians outside of the vehicle of the danger.

Custom System Configurations – Thanks to the advanced engineering by the PRECO Electronics® Engineers, the technology behind PreView® Sensors can easily integrate or control your vehicles existing or new safety systems.

Warranty Information

MANUFACTURER LIMITED WARRANTY AND LIMITATION OF LIABILITY

Manufacturer warrants that on the Date of Purchase this Product will conform to Manufacturer's published specifications for the product, which are available from Manufacturer on request, and Manufacturer warrants that the product is free from defects in materials and workmanship. This Limited Warranty extends for twelve (12) months from the date of shipment. Manufacturer will, at its option, repair or replace any product found by Manufacturer to be defective and subject to this Limited Warranty.

This Limited Warranty does not apply to parts or products that are misused; abused; modified; damaged by accident, fire or other hazard; improperly installed or operated; or not maintained in accordance with the maintenance procedures set forth in Manufacturer's Installation and Operating Instructions.

To obtain warranty service, you must ship the product(s) to the specified Manufacturer location within thirty (30) days from expiration of the warranty period. To obtain warranty service you must call PRECO Electronics® Customer Service at 866-977-7236 or 208-323-1000, or fax your request to 208-323-1034. Customer Service will issue warranty authorization and further instructions. You must prepay shipping charges and use the original shipping container or equivalent.

EXCLUSION OF OTHER WARRANTIES: MANUFACTURER MAKES NO OTHER WARRANTIES, EXPRESSED, IMPLIED OR STATUTORY. THE IMPLIED WARRANTIES FOR MERCHANTABILITY OR FITNESS FOR A PARTICULAR PURPOSE ARE HEREBY EXCLUDED AND SHALL NOT APPLY TO THE PRODUCT. BUYER'S SOLE AND EXCLUSIVE REMEDY IN CONTRACT, TORT OR UNDER ANY OTHER THEORY AGAINST MANUFACTURER RESPECTING THE PRODUCT AND ITS USE SHALL BE THE REPLACEMENT OR REPAIR OF THE PRODUCT AS DESCRIBED ABOVE. **LIMITATION OF LIABILITY:** IN THE EVENT OF LIABILITY FOR DAMAGES ARISING OUT OF THIS LIMITED WARRANTY OR ANY OTHER CLAIM RELATED TO MANUFACTURER'S PRODUCTS, MANUFACTURER'S LIABILITY FOR DAMAGES SHALL BE LIMITED TO THE AMOUNT PAID FOR THE PRODUCT AT THE TIME OF ORIGINAL PURCHASE. IN NO EVENT SHALL MANUFACTURER BE LIABLE FOR LOST PROFITS, THE COST OF SUBSTITUTE EQUIPMENT OR LABOR, PROPERTY DAMAGE, OR OTHER SPECIAL, CONSEQUENTIAL OR INCIDENTAL DAMAGES BASED UPON ANY CLAIM FOR BREACH OF CONTRACT, NEGLIGENCE OR OTHER CLAIM, EVEN IF MANUFACTURER OR A MANUFACTURER'S REPRESENTATIVE HAS BEEN ADVISED OF THE POSSIBILITY OF SUCH DAMAGES.

Manufacturer shall have no further obligation or liability with respect to the product or its sale, operation and use, and Manufacturer neither assumes nor authorizes the assumption of any other obligation or liability in connection with such product.

This Limited Warranty gives you specific legal rights, and you may also have other legal rights which vary from state to state. Some states do not allow the exclusion or limitation of incidental or consequential damages, so the above exclusion or limitation may not apply to you.

Any oral statements or representations about the product which may have been made by salesmen or Manufacturer representatives do not constitute warranties. This Limited Warranty may not be amended, modified or enlarged, except by a written agreement signed by an authorized official of Manufacturer which expressly refers to this Limited Warranty.

Proudly developed by

PRECO[®]
ELECTRONICS

10335 W. Emerald St.
Boise, Idaho 83704
www.precos.com
+1.866.977.7326

3700042D